

HAP = Höhenausgleichsprofil wie dargestellt / height adjustment profile as shown

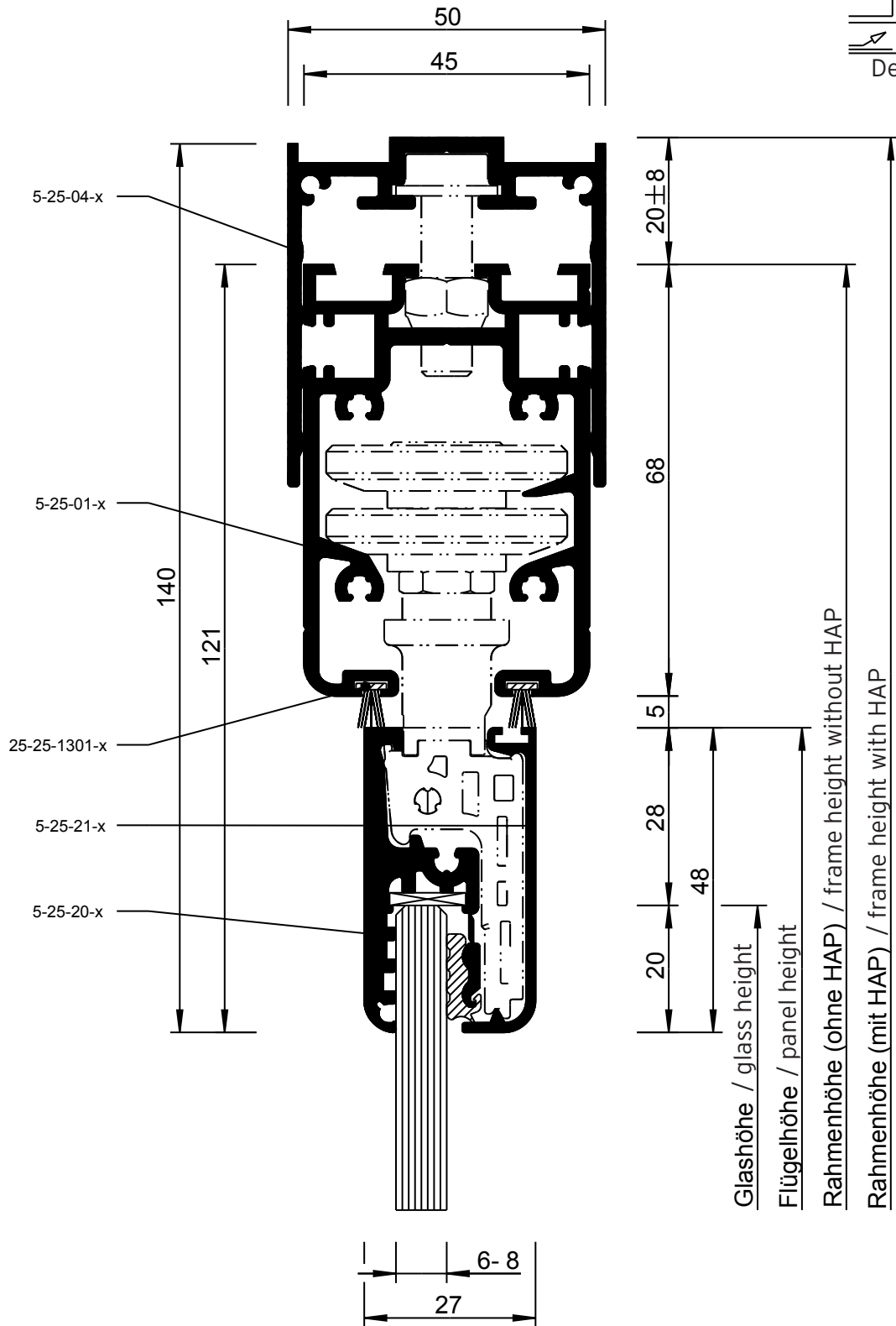

HAP = Höhenausgleichsprofil wie dargestellt / height adjustment profile as shown

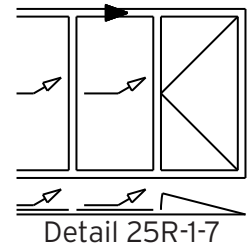
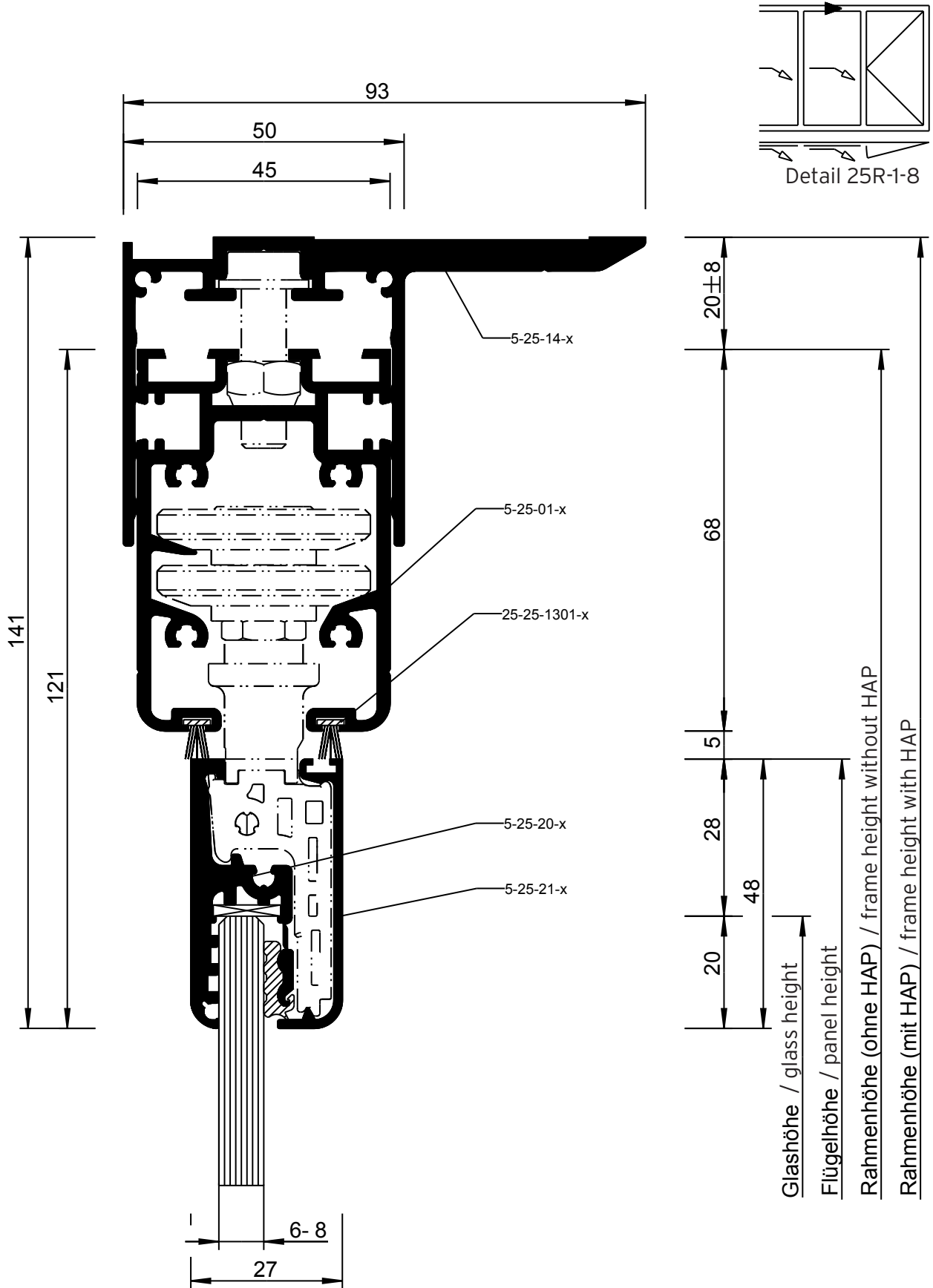

HAP = Höhenausgleichsprofil wie dargestellt / height adjustment profile as shown

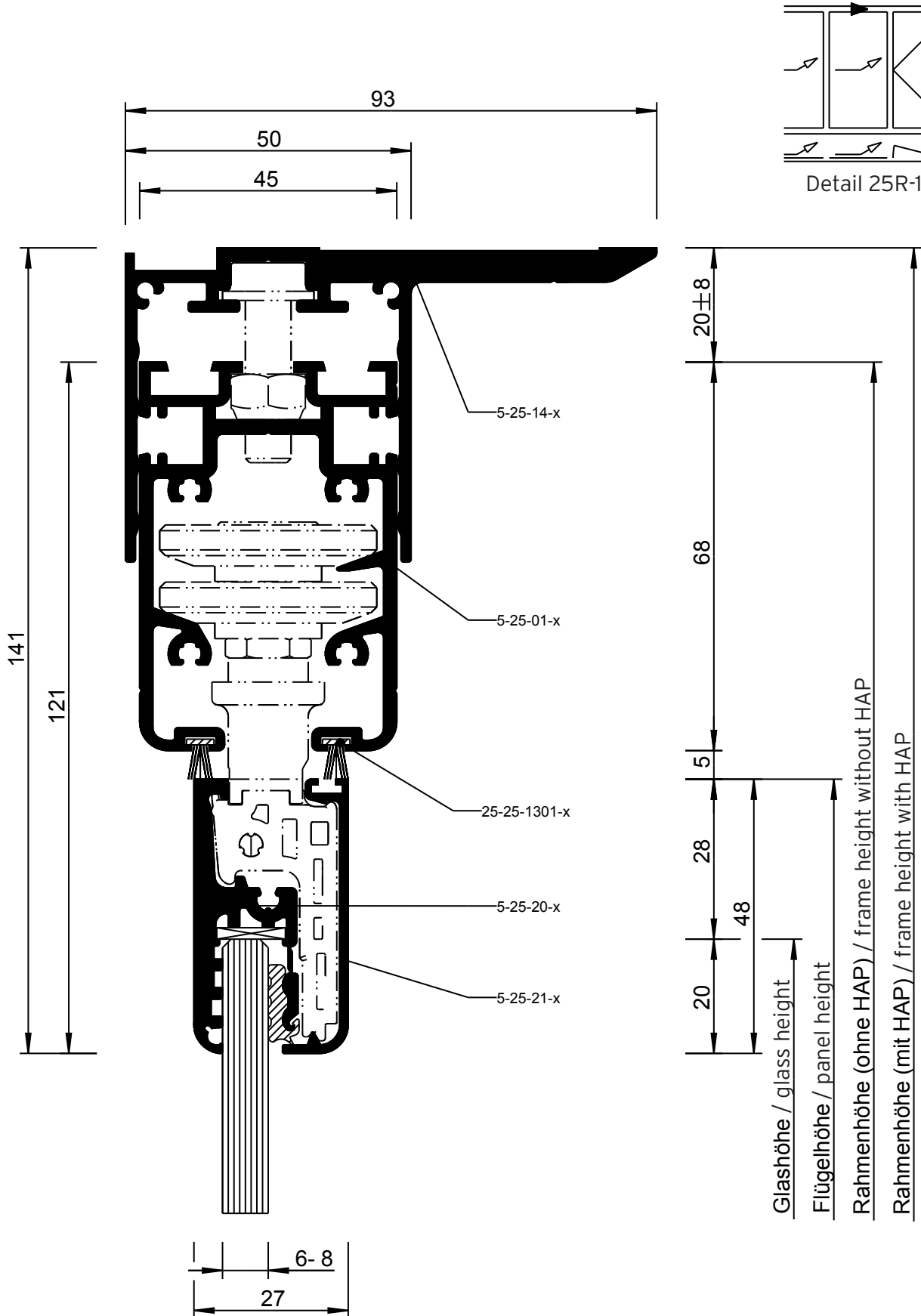

HAP = Höhenausgleichsprofil wie dargestellt / height adjustment profile as shown

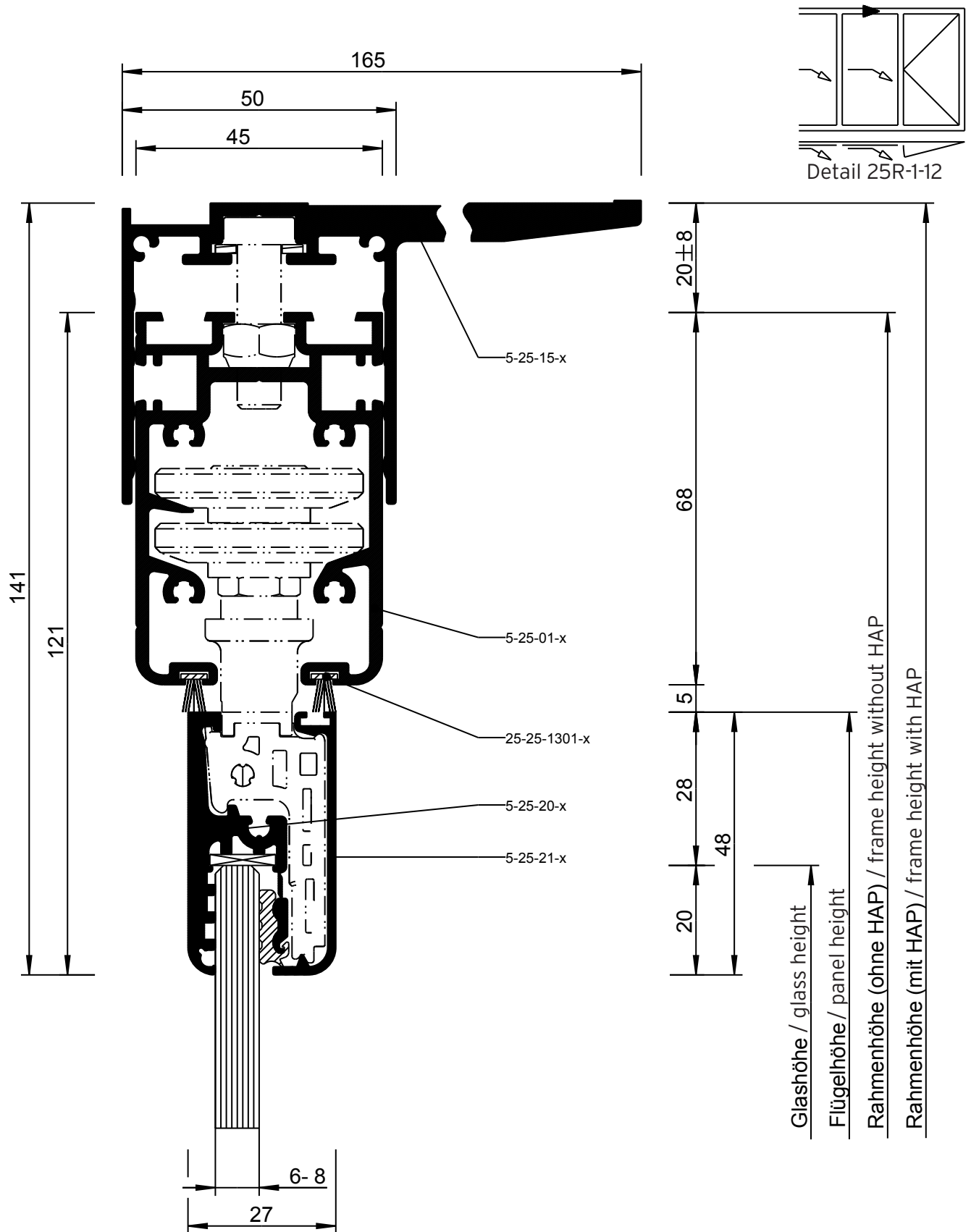

HAP = Höhenausgleichsprofil wie dargestellt / height adjustment profile as shown

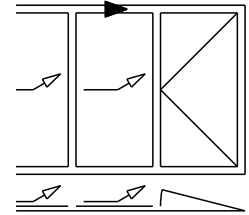

Detail 25R-1-13

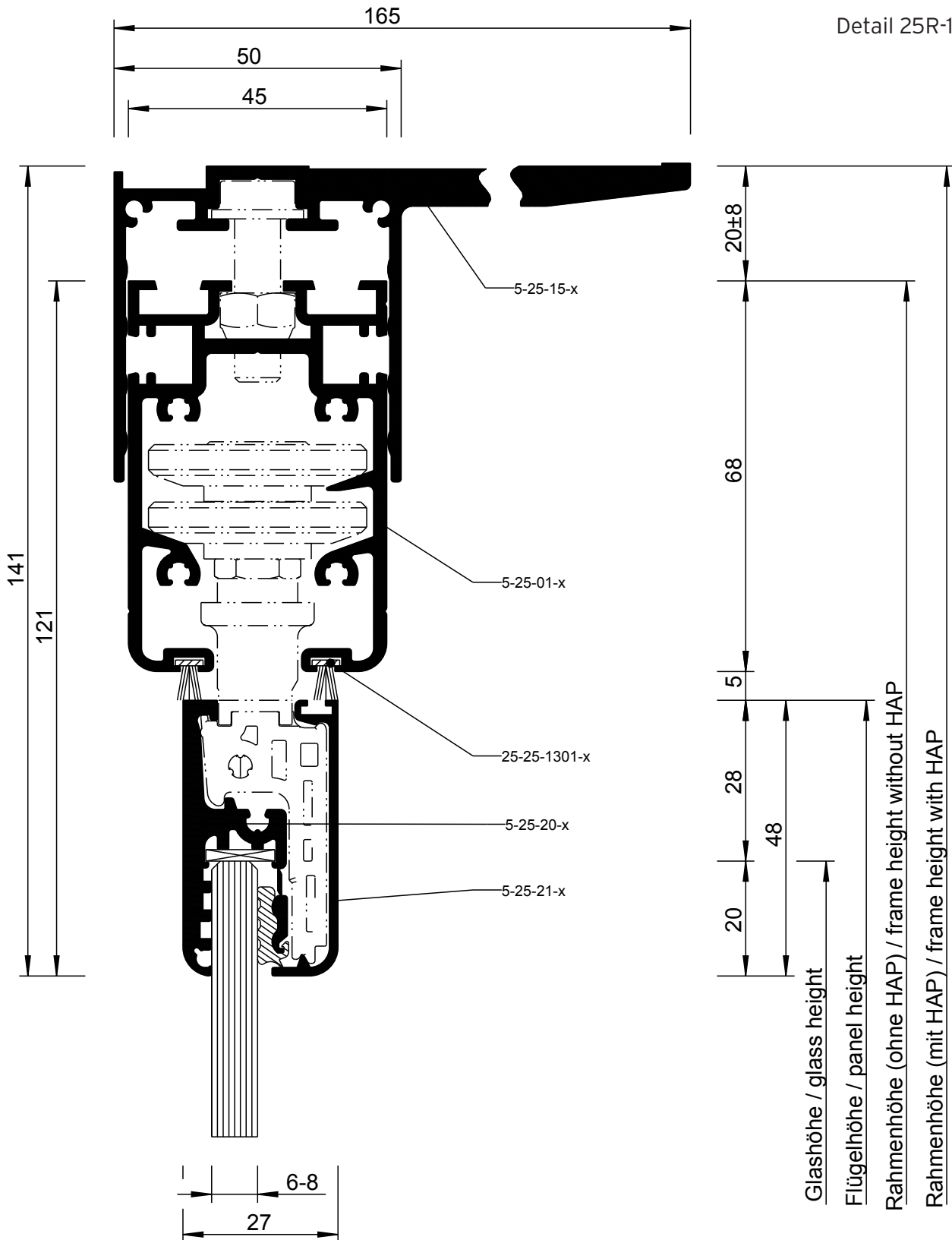

HAP = Höhenausgleichsprofil wie dargestellt / height adjustment profile as shown

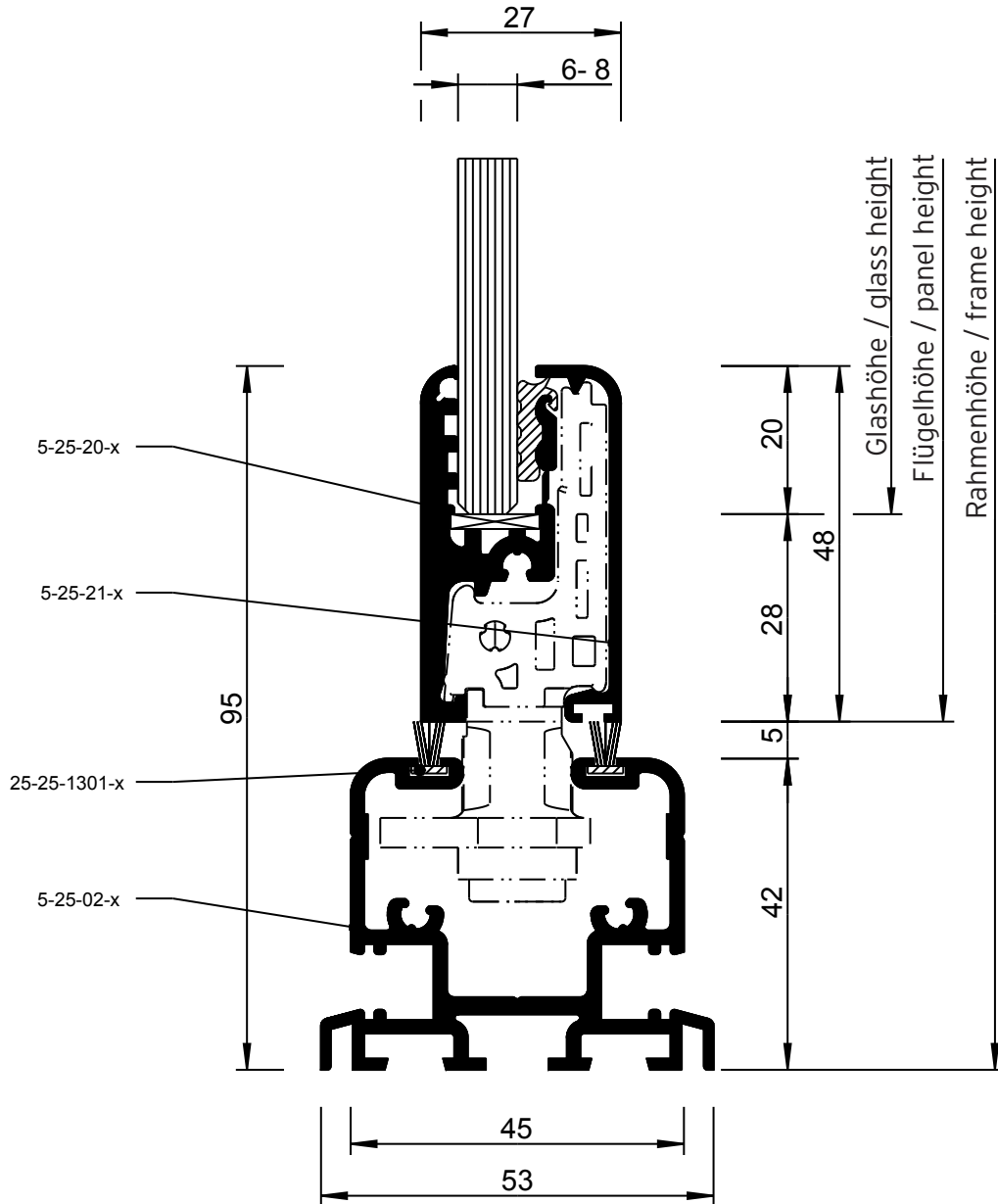
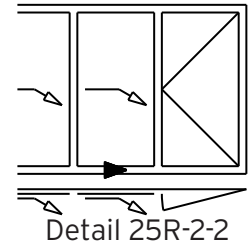

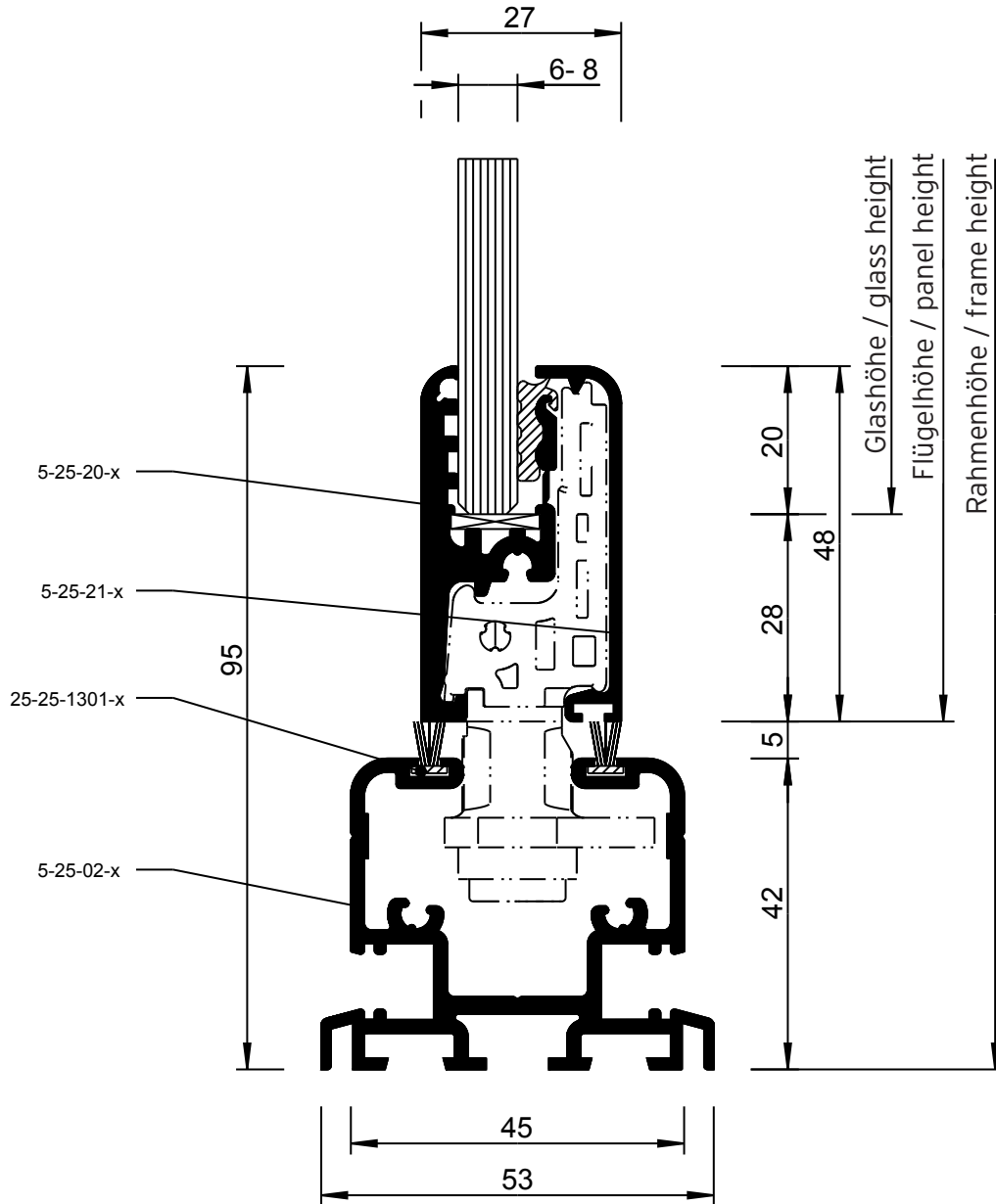
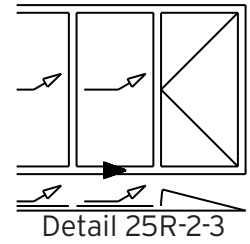

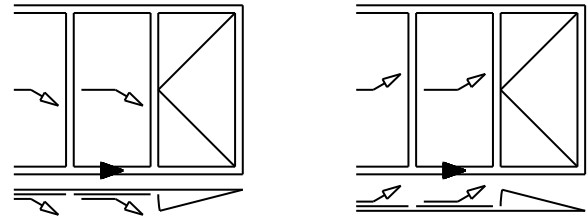

Detail 25R-2-4

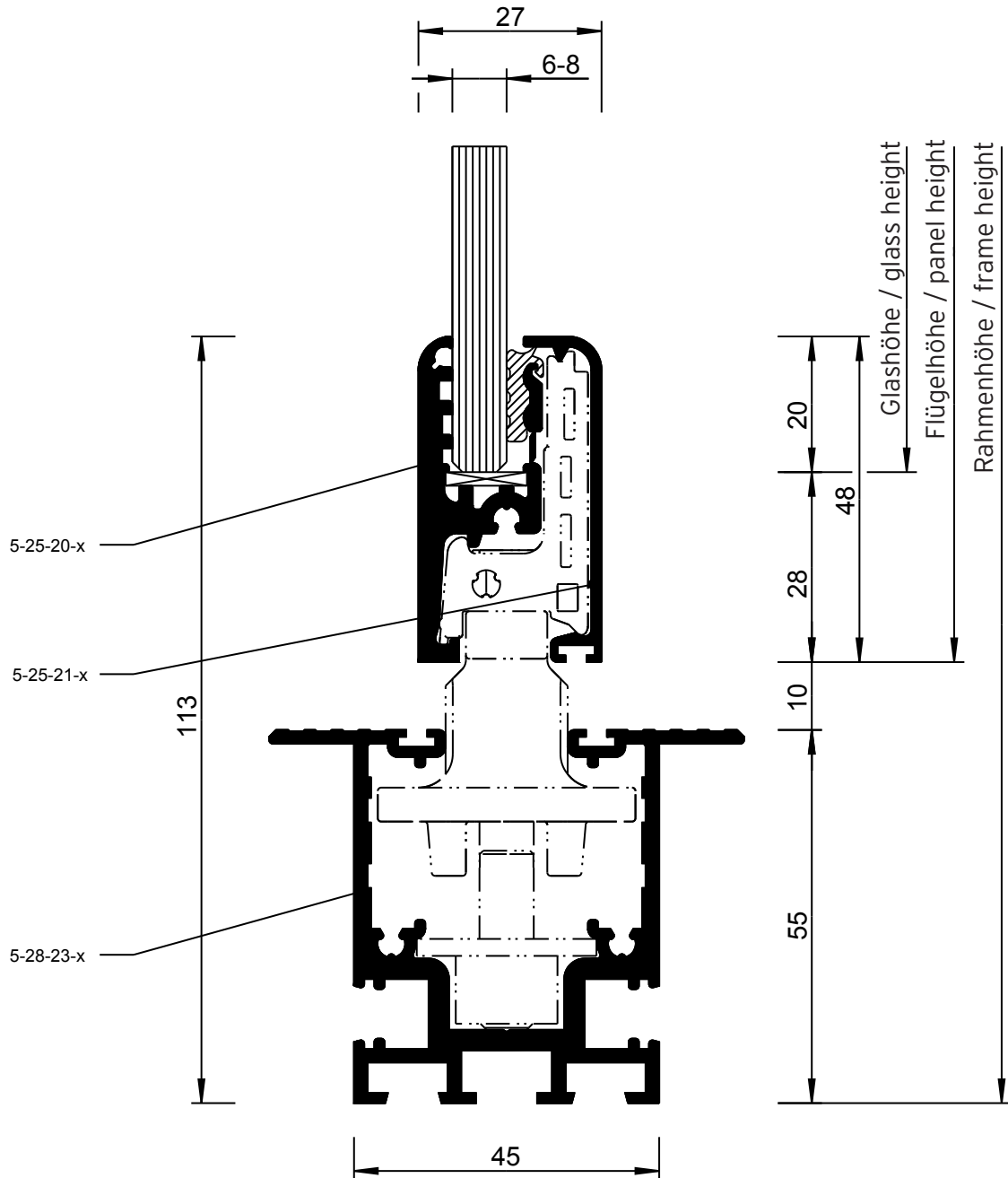

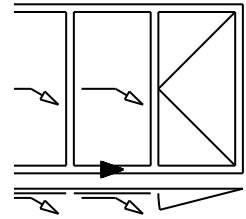

Detail 25R-2-14

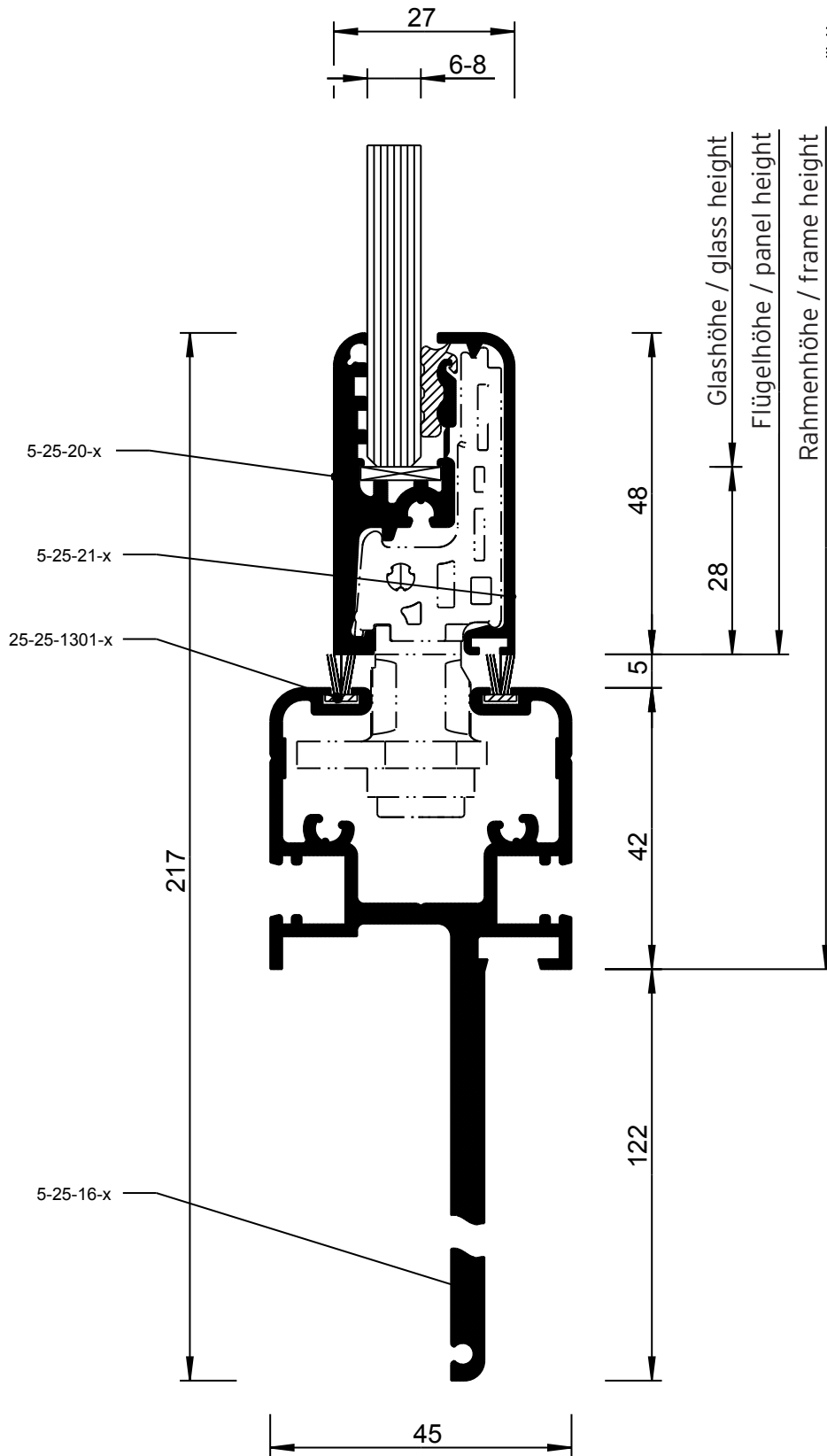

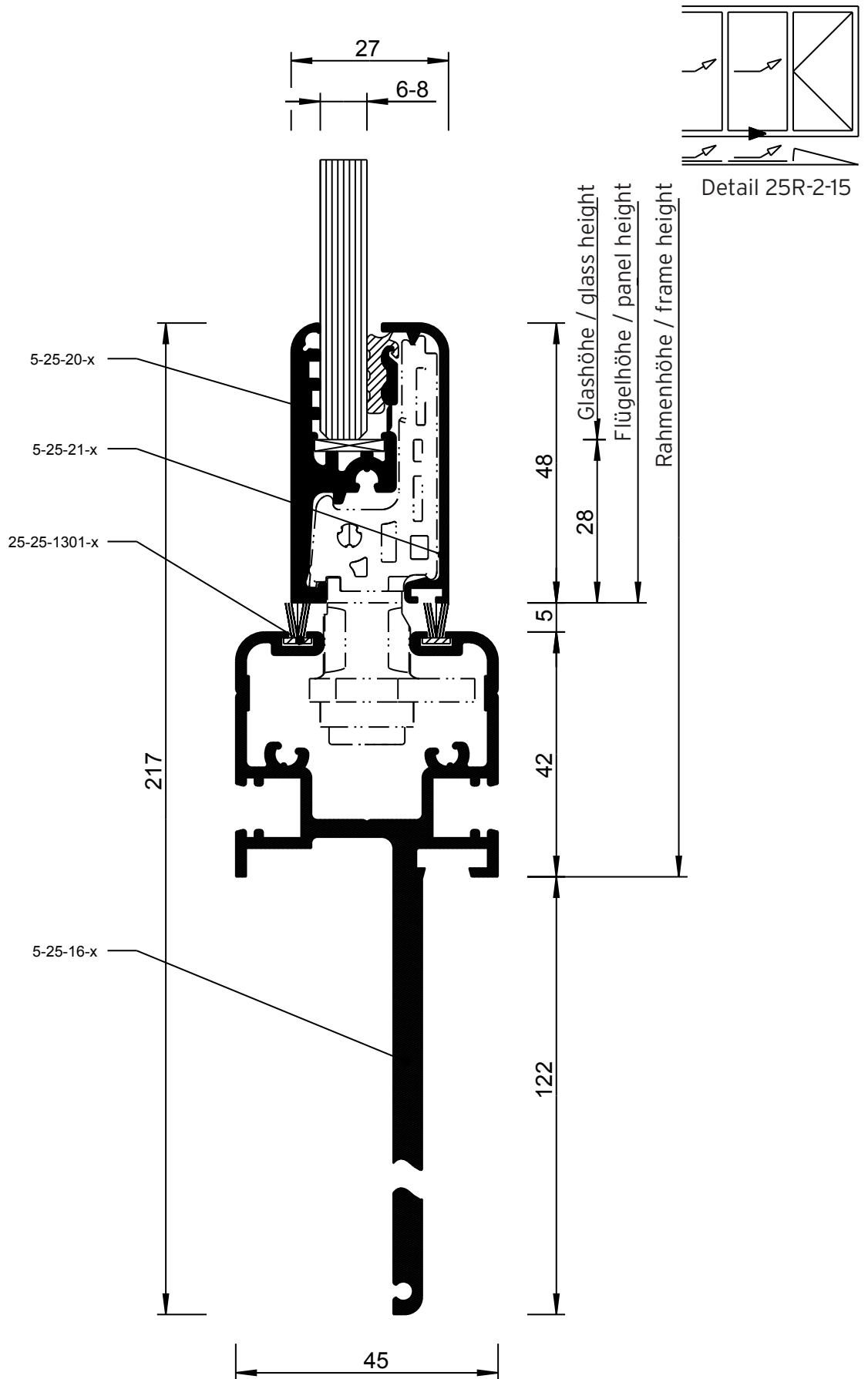

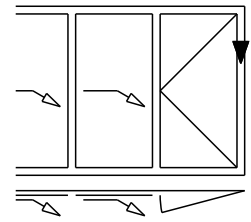

Detail 25R-3-2

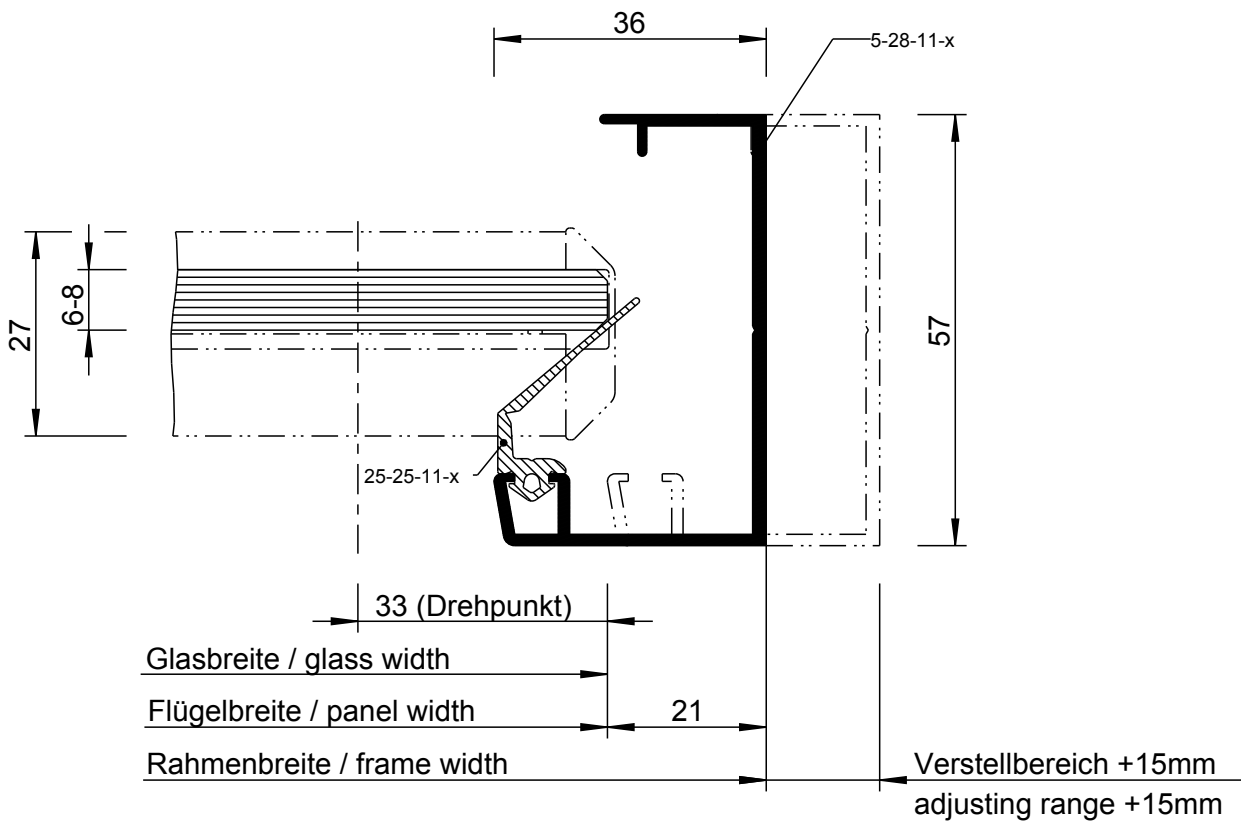

Drehpunkt = center of rotation

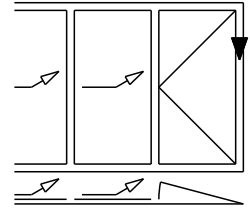

Detail 25R-3-3

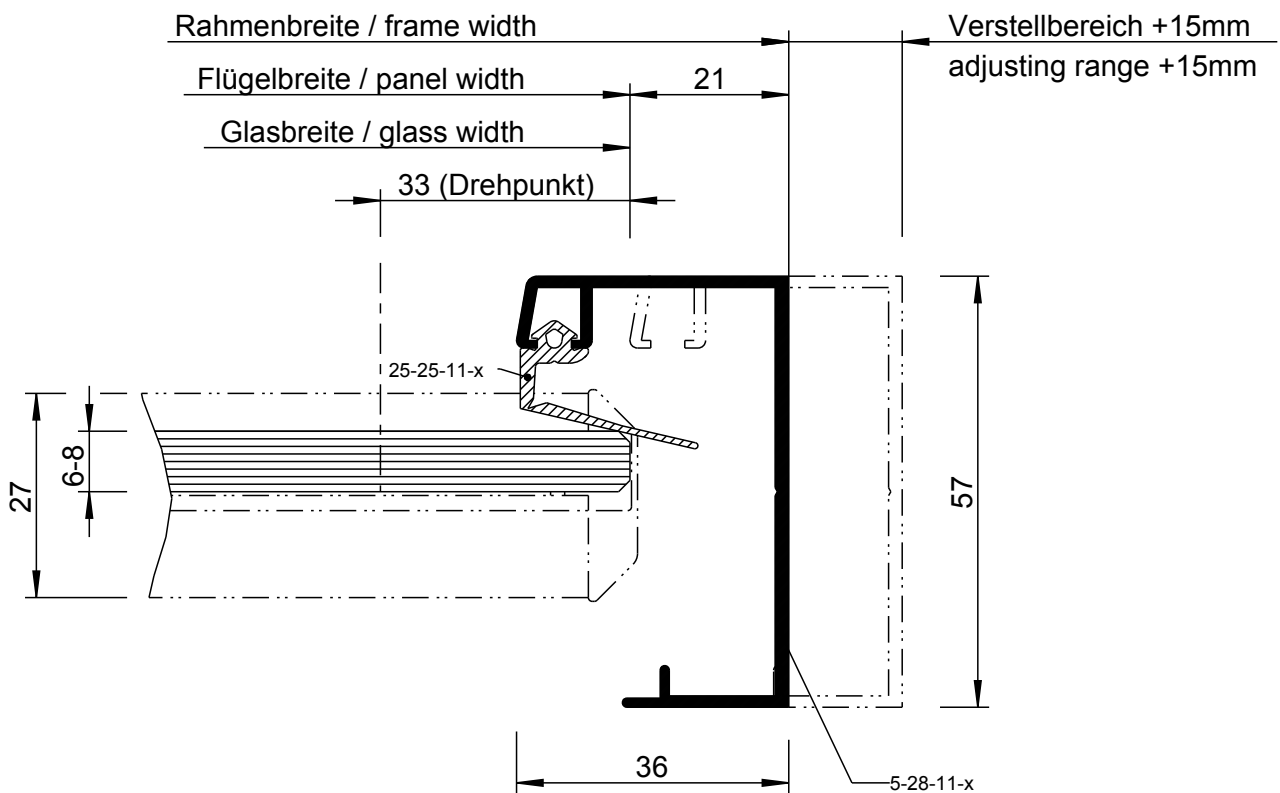

Drehpunkt = center of rotation

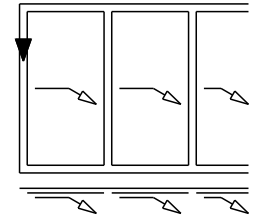

Detail 25R-6-2

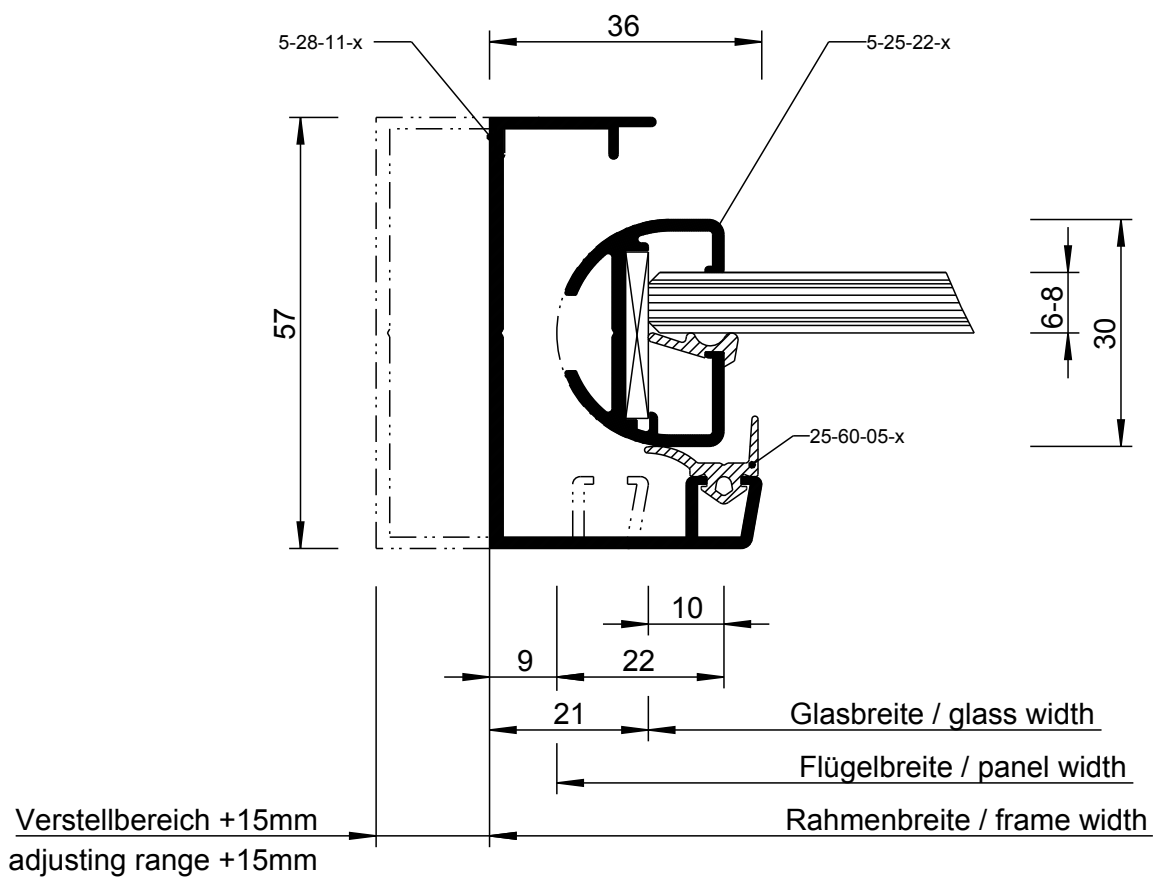

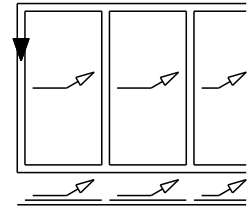

Detail 25R-6-3

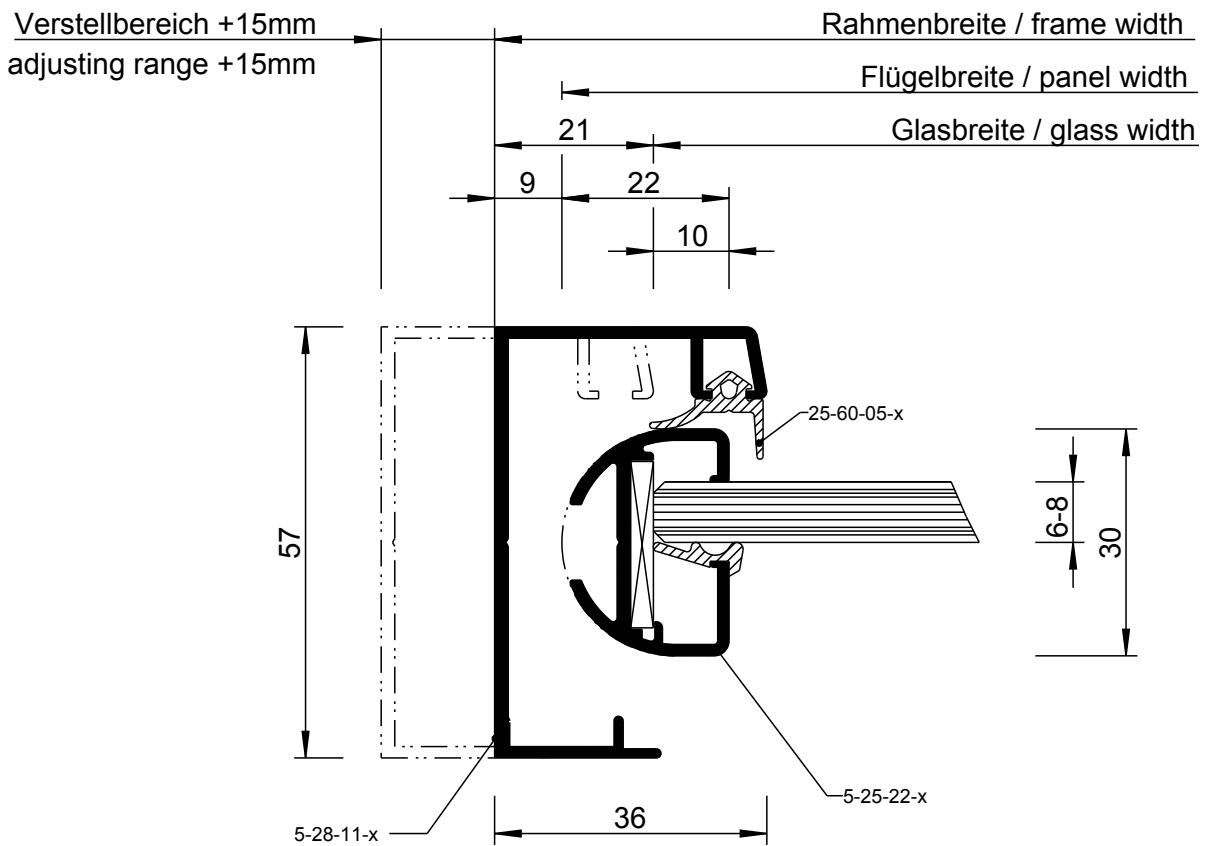

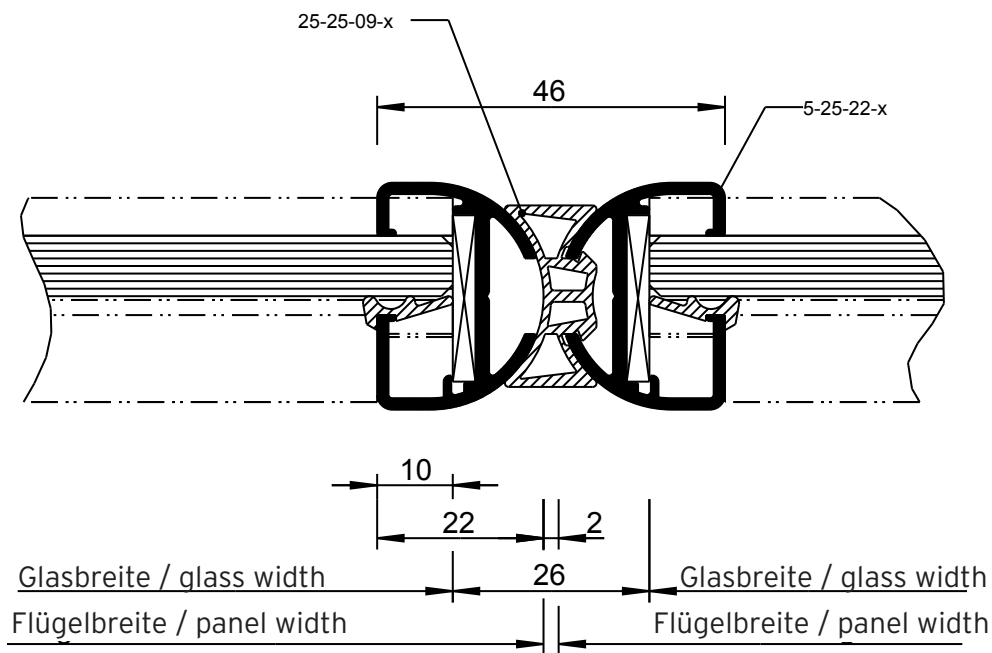
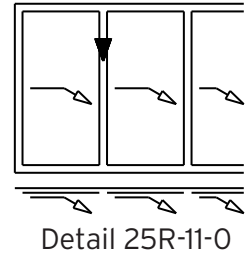

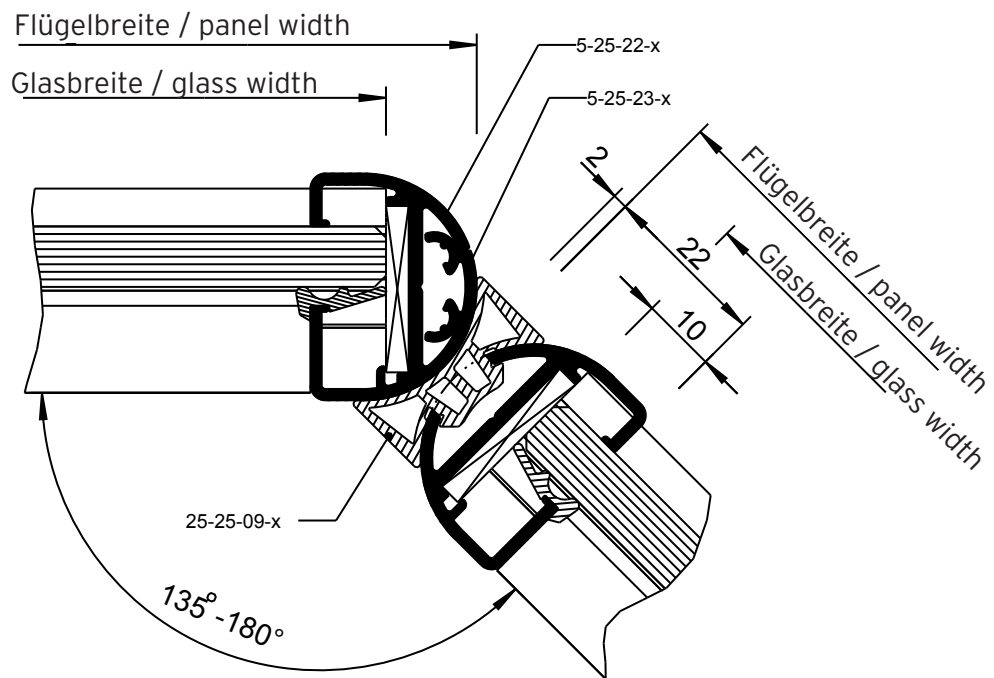
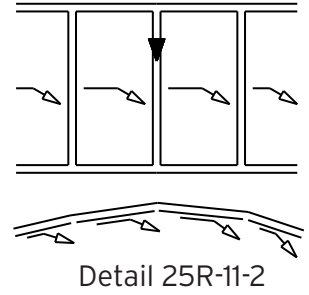

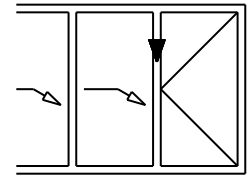

Detail 25R-11-4

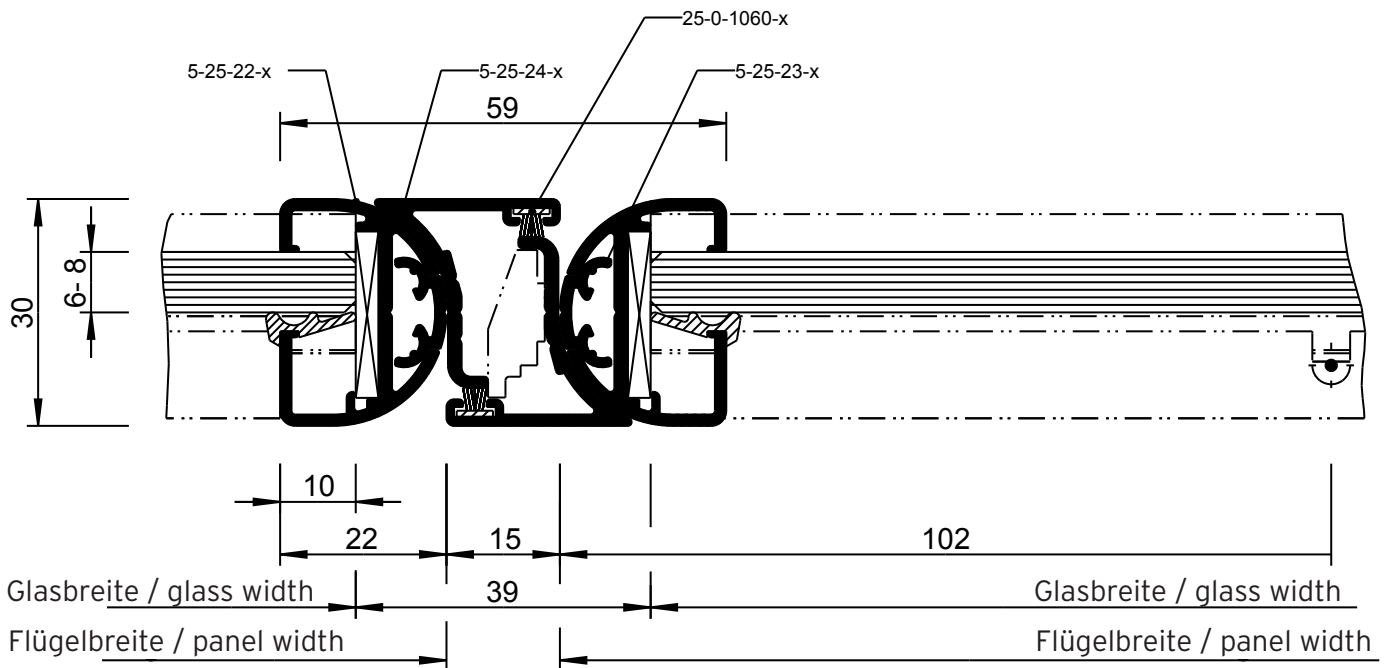

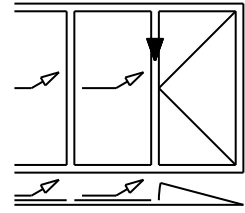

Detail 25R-11-5

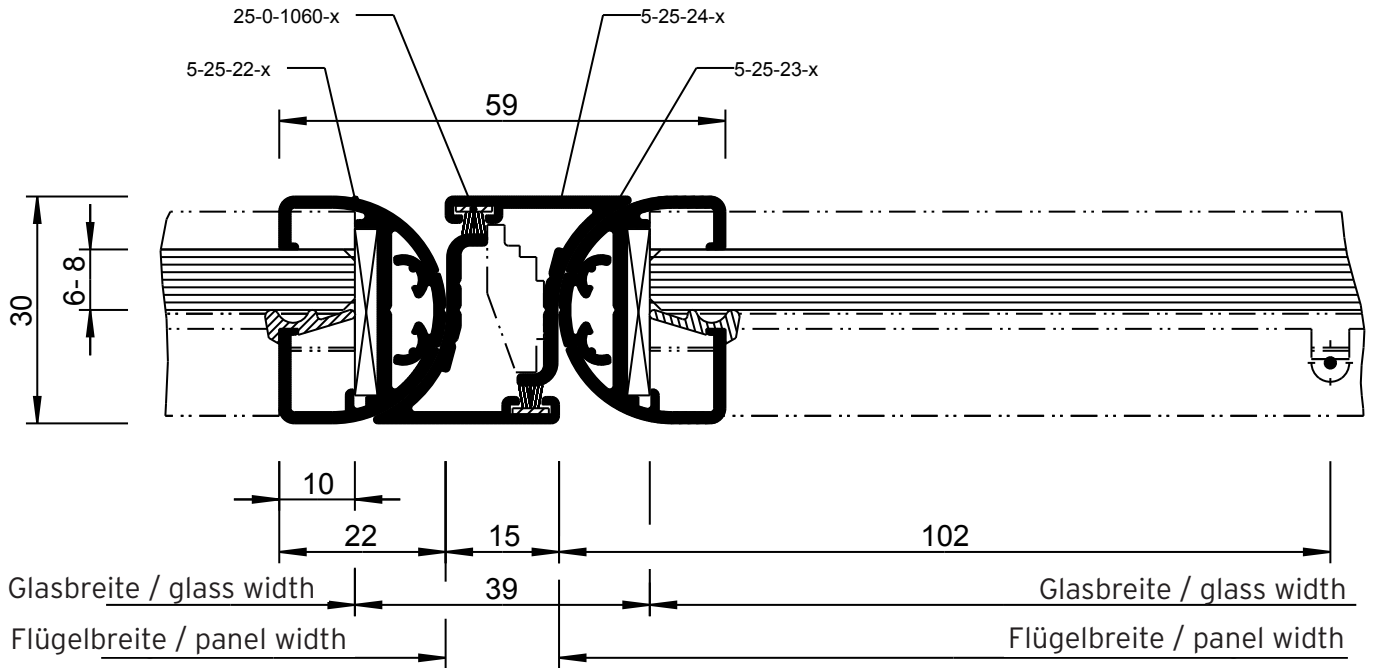

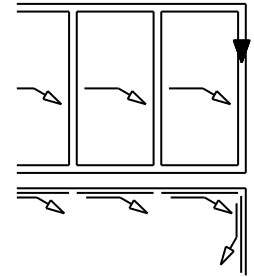

Detail 25R-11-8

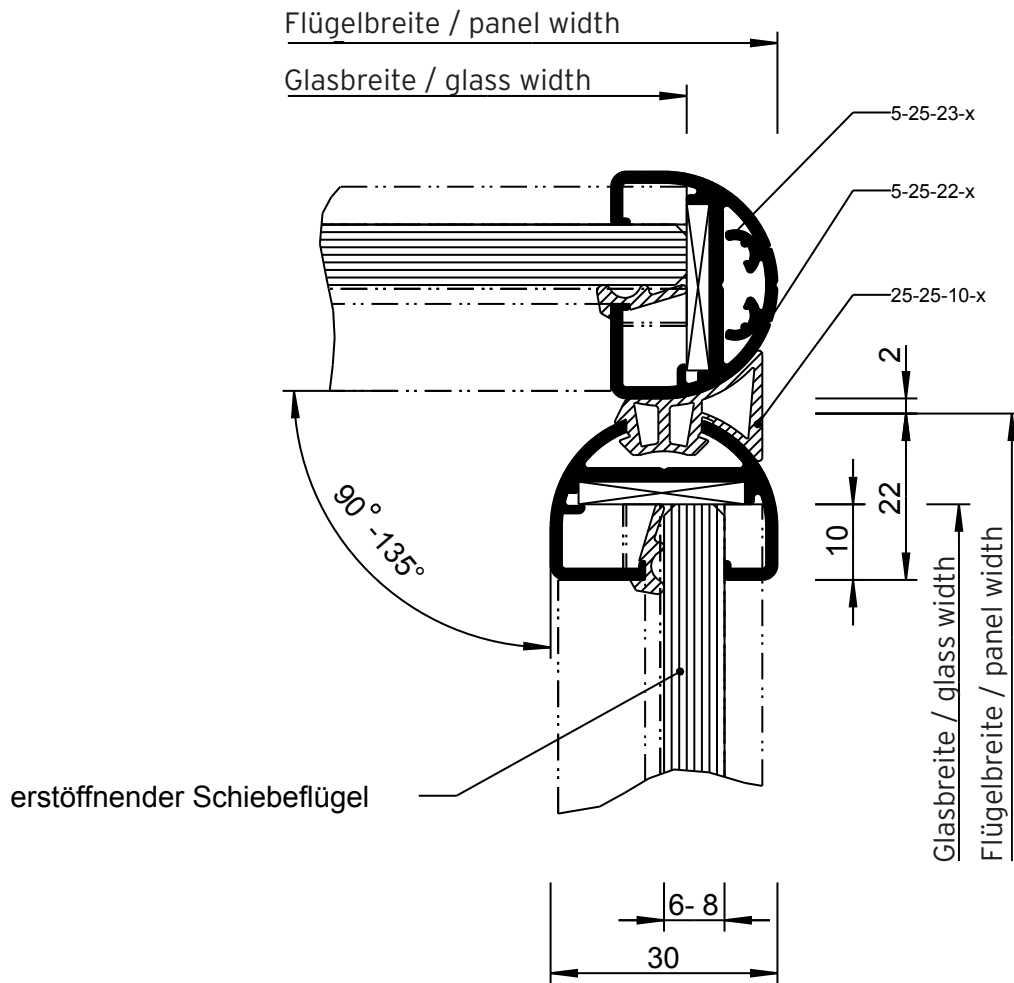

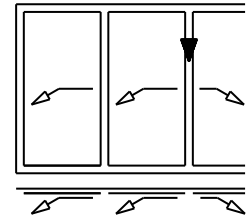

Detail 25R-11-12

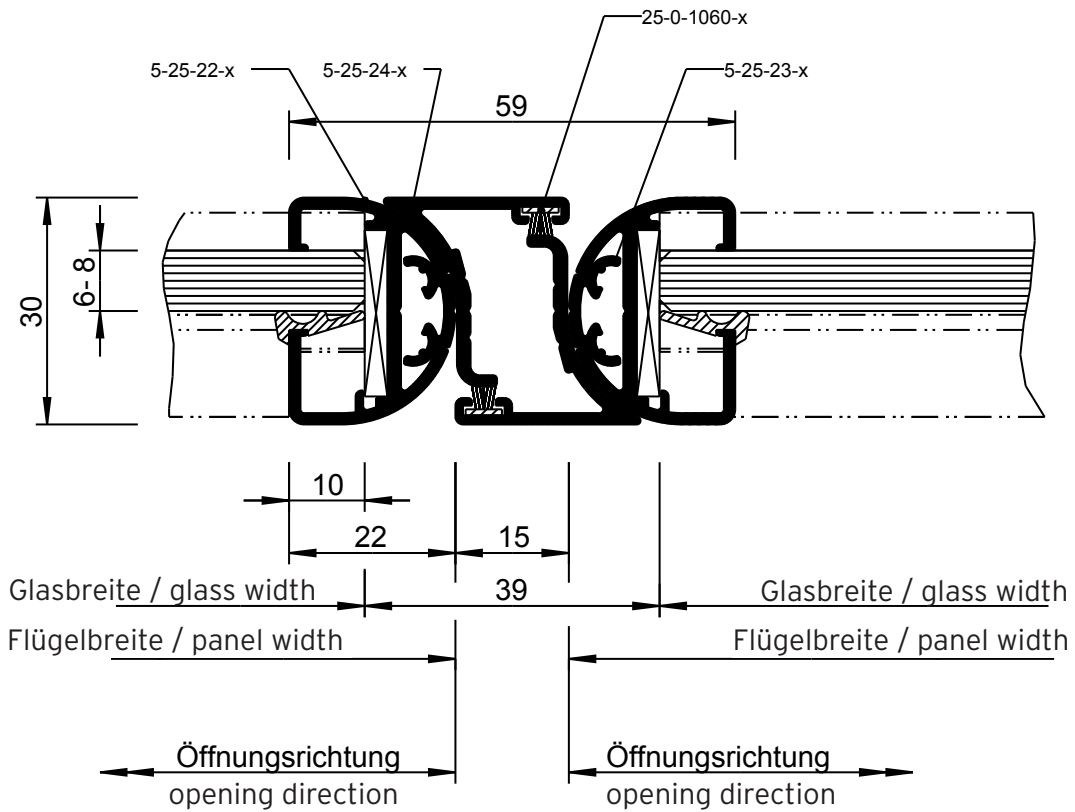

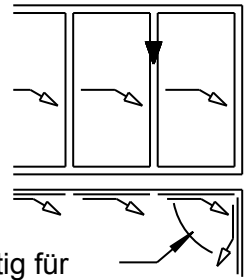

gültig für
Winkel 90°-135°
Detail 25R-11-14

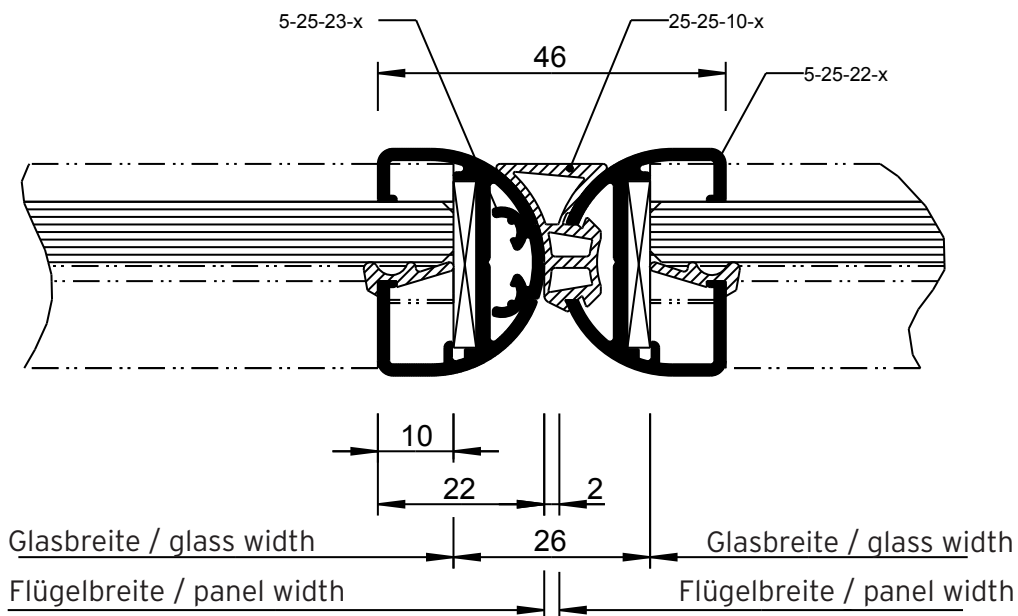

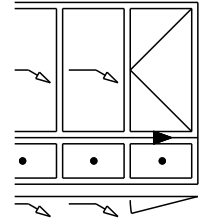

Detail SL25R-37-2

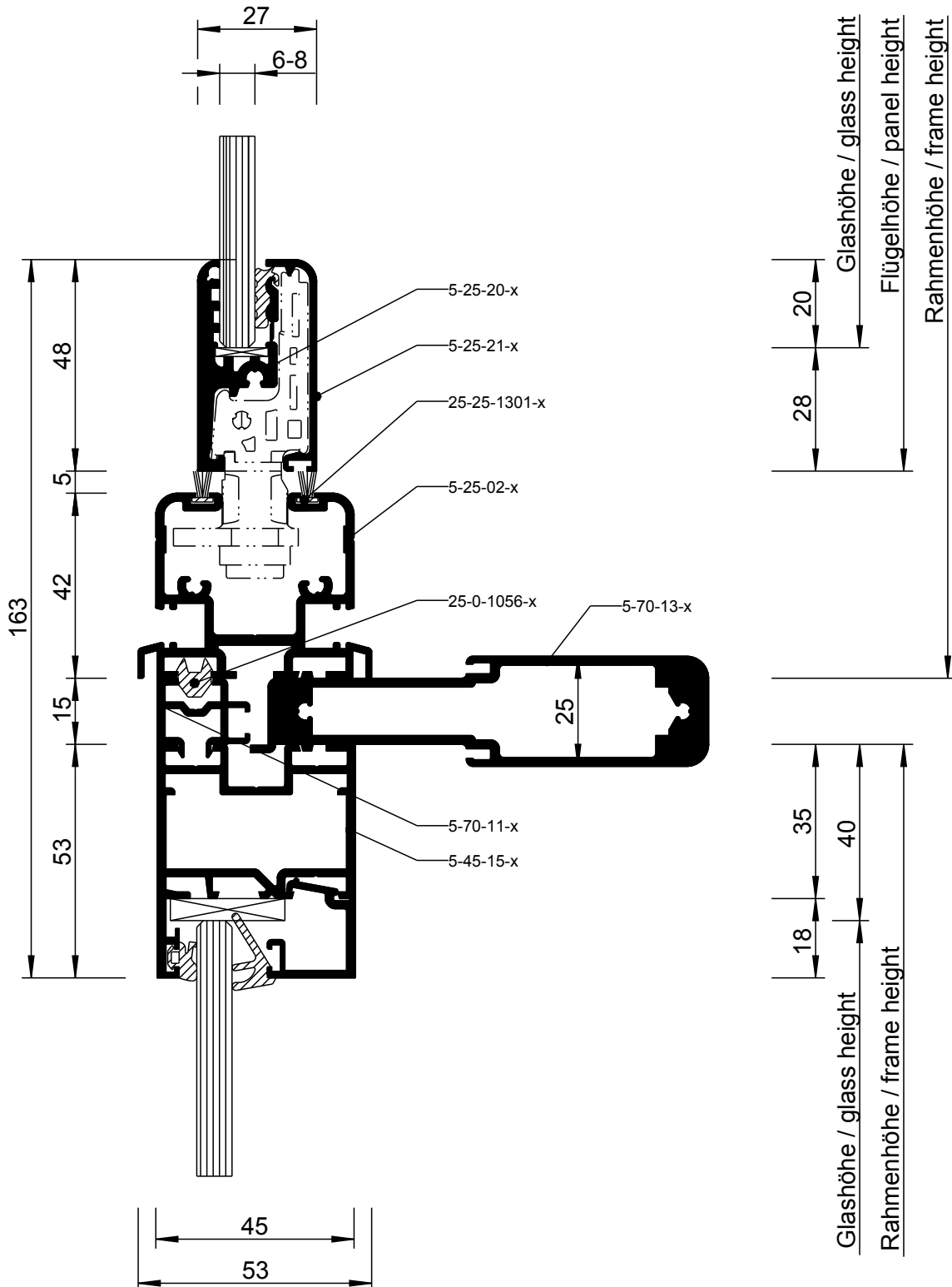

Ansicht nicht maßstäblich! / Not to scale.